

Name:..... Date:..... Level:.....
 (All depths measured from RKB)
 Measured Depth:.....ft. True Vertical Depth:.....ft.
 Measured Depth to Casing Shoe:.....ft. Casing Shoe TVD:.....ft.
 Water Depth:.....ft. Air Gap:.....ft.

CAPACITIES AND VOLUMES

DRILL STRING DATA	O.D. (in)	I.D. (in)	Wt. (lb/ft)	CAPACITY (bbl/ft)	x	LENGTH (ft)	=	VOLUME (bbls)
DRILL PIPE								
HWDP								
DRILL COLLARS								
CHECK THAT TOTAL LENGTH = MEASURED DEPTH								
							➡	
							Total Length	Total Drillstring
							(ft)	(bbls)

ANNULUS DATA	CAPACITY (bbl/ft)	x	LENGTH (ft)	=	VOLUME (bbls)
CHOKE LINE					
DP/HWDP IN CASING					
DP/HWDP IN OPEN HOLE					
COLLARS IN OPEN HOLE					
Note: Total Length may not equal Measured Depth if choke line is longer than the riser.					
					➡
					Total Length
					(ft)
					Total Annulus
					(bbls)

Bit to Shoe Volume

(bbls)

TOTAL SYSTEM VOLUME

TOTAL DRILLSTRING (SURFACE TO BIT)	TOTAL ANNULUS (BIT TO SURFACE)	TOTAL SYSTEM VOLUME
<div style="border: 1px solid black; width: 100%; height: 30px; display: inline-block;"></div> (bbls)	+ <div style="border: 1px solid black; width: 100%; height: 30px; display: inline-block;"></div> (bbls)	= <div style="border: 1px solid black; width: 100%; height: 30px; display: inline-block;"></div> (bbls)

RISER DATA

RISER DATA	CAPACITY (DP/RISER) (bbl/ft)	x	LENGTH (ft)	=	VOLUME (bbls)
DP/RISER ANNULUS VOLUME					

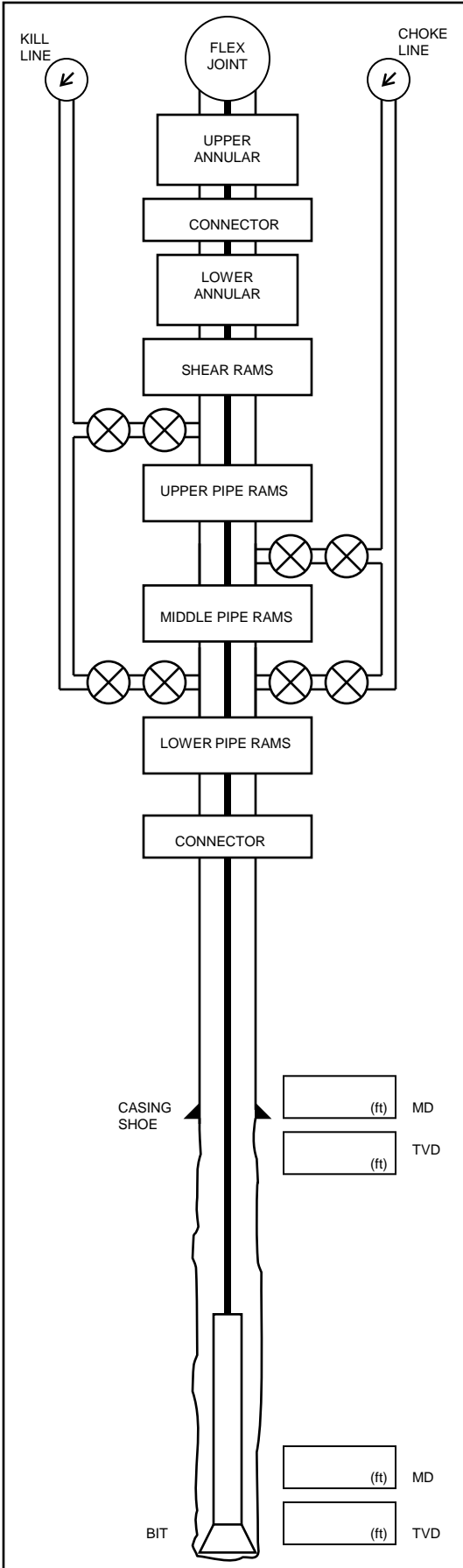

Read and record SLOW CIRCULATING RATES

	Pump No.		Pump Output		
	<input type="text"/> <small>(bbls/stk)</small>		<input type="text"/> <small>(bbls/stk)</small>		
<u>S.C.R</u>	<u>CHOKE LINE</u>	-	<u>RISER</u>	=	<u>CHOKE LINE FRICTION</u>
20 spm	<input type="text"/> <small>(psi)</small>		<input type="text"/> <small>(psi)</small>		<input type="text"/> <small>(psi)</small>
30 spm	<input type="text"/> <small>(psi)</small>		<input type="text"/> <small>(psi)</small>		<input type="text"/> <small>(psi)</small>
40 spm	<input type="text"/> <small>(psi)</small>		<input type="text"/> <small>(psi)</small>		<input type="text"/> <small>(psi)</small>

Drill String Data

Drill String Volume (bbls)	÷	Pump Output (bbls/stk)	=	Surface to Bit Strokes
<input type="text"/>		<input type="text"/>		<input type="text"/>
Surface to Bit Strokes	÷	Slow Circulating Rate (spm)	=	Surface to Bit Time
<input type="text"/>		<input type="text"/>		<input type="text"/> <small>(min)</small>

Open Hole Data

Bit to Shoe Volume (bbls)	÷	Pump Output (bbls/stk)	=	Bit to Shoe Strokes
<input type="text"/>		<input type="text"/>		<input type="text"/>
Bit to Shoe Strokes	÷	Slow Circulating Rate (spm)	=	Bit to Shoe Time
<input type="text"/>		<input type="text"/>		<input type="text"/> <small>(min)</small>

Annulus Data

Bit to Surface Volume (bbls)	÷	Pump Output (bbls/stk)	=	Bit to Surface Strokes
<input type="text"/>		<input type="text"/>		<input type="text"/>
Bit to Surface Strokes	÷	Slow Circulating Rate (spm)	=	Bit to Surface Time
<input type="text"/>		<input type="text"/>		<input type="text"/> <small>(min)</small>

Riser Data

Volume (bbls)	÷	Pump Output (bbls/stk)	=	BOP to Surface Strokes
<input type="text"/>		<input type="text"/>		<input type="text"/>
BOP to Surface Strokes	÷	Slow Circulating Rate (spm)	=	BOP to Surface Time
<input type="text"/>		<input type="text"/>		<input type="text"/> <small>(min)</small>

Name:

Read and record SIDPP, SICP and PIT GAIN

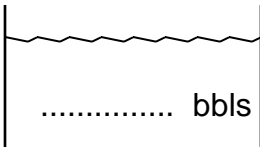
<p><u>S.I.D.P.P.</u></p> <div style="border: 1px solid black; border-radius: 50%; width: 150px; height: 100px; margin: 0 auto; display: flex; align-items: center; justify-content: center;"> psi </div> <p>Day:</p>	<p><u>PIT GAIN</u></p> <div style="border: 1px solid black; width: 150px; height: 60px; margin: 0 auto; display: flex; align-items: center; justify-content: center;">  </div> <p>..... bbls</p> <p>Date:</p>	<p><u>S.I.C.P.</u></p> <div style="border: 1px solid black; border-radius: 50%; width: 150px; height: 100px; margin: 0 auto; display: flex; align-items: center; justify-content: center;"> psi </div> <p>Time:</p>
--	---	---

Max. Mud Wt.

Surface Leak Off Test <input style="width: 100%; height: 20px;" type="text"/> (psi)	÷	Casing T.V.D. from RKB <input style="width: 100%; height: 20px;" type="text"/> (ft)	÷	<div style="border: 1px solid black; padding: 2px; display: inline-block;">0.052</div>	+	Leak Off Test Mud Weight <input style="width: 100%; height: 20px;" type="text"/> (ppg)	=	Maximum Mud Weight <input style="width: 100%; height: 20px;" type="text"/> (ppg)
<u>OR</u>								
				Formation Breakdown Gradient <input style="width: 100%; height: 20px;" type="text"/> (psi/ft)	÷	<div style="border: 1px solid black; padding: 2px; display: inline-block;">0.052</div>	=	Maximum Mud Weight <input style="width: 100%; height: 20px;" type="text"/> (ppg)

M.A.A.S.P.

Maximum Mud Weight <input style="width: 100%; height: 20px;" type="text"/> (ppg)	-	Drilling Mud Weight <input style="width: 100%; height: 20px;" type="text"/> (ppg)] X	<div style="border: 1px solid black; padding: 2px; display: inline-block;">0.052</div>	X	Casing T.V.D. from RKB <input style="width: 100%; height: 20px;" type="text"/> (ft)	=	Maximum Allowable Annulus Surface Pressure <input style="width: 100%; height: 20px;" type="text"/> (psi)
--	---	---	-----	--	---	---	---	--

M.A.C.P.

Casing Yield <input style="width: 100%; height: 20px;" type="text"/>	X	<div style="border: 1px solid black; padding: 2px; display: inline-block;">0.8</div>	=	Maximum Allowable Casing Pressure <input style="width: 100%; height: 20px;" type="text"/> (psi)
---	---	--	---	---

Kill Mud Wt.

S.I.D.P.P. <input style="width: 100%; height: 20px;" type="text"/> (psi)	÷	T.V.D. from RKB <input style="width: 100%; height: 20px;" type="text"/> (ft)	÷	<div style="border: 1px solid black; padding: 2px; display: inline-block;">0.052</div>	+	Drilling Mud Weight <input style="width: 100%; height: 20px;" type="text"/> (ppg)	=	Kill Mud Weight <input style="width: 100%; height: 20px;" type="text"/> (ppg)
--	---	--	---	--	---	---	---	---

NEW M.A.A.S.P.

Maximum Mud Weight <input style="width: 100%; height: 20px;" type="text"/> (ppg)	-	Kill Mud Weight <input style="width: 100%; height: 20px;" type="text"/> (ppg)] X	<div style="border: 1px solid black; padding: 2px; display: inline-block;">0.052</div>	X	Casing T.V.D. from RKB <input style="width: 100%; height: 20px;" type="text"/> (ft)	=	New Maximum Allowable Annulus Surface Pressure <input style="width: 100%; height: 20px;" type="text"/> (psi)
--	---	---	-----	--	---	---	---	--

